

CE TEST REPORT
for
High Power LED Driver
Model No.: HPD004B

of

Applicant: Semicon-Optronics Channel Corp.
Address: 9F, No.563, Sec. 1, Beising Rd., Jhudong, Hsinchu, 31042, Taiwan

Tested and Prepared
by



ETS Product Service (Taiwan) Co., Ltd.

FCC Registration No.: 930600

Industry Canada filed test laboratory Reg. No. IC 5679

A2LA Accredited No.: 2300.01

PTCRB Accredited Type Certification Test House



Report No.: W6M20707-8262-E-11

Testing laboratory

Location

ETS Product Service (Taiwan) Co., Ltd.

OATS

No.5-1, Shuang Sing Village,
LiShuei Rd., Wanli Township,
Taipei County 207, Taiwan (R.O.C.)

Company

ETS Product Service (Taiwan) Co., Ltd.

6F, NO. 58, LANE 188, RUEY-KUANG RD.

NEIHU, TAIPEI 114, TAIWAN R.O.C.

Tel : 886-2-66068877

Fax : 886-2-66068879

Test location, where different from ETS Product Service (Taiwan) Co., Ltd.

Name : ./.
Street : ./.
Town : ./.
Country : ./.
Telephone : ./.
Fax : ./.

Details of applicant

Name : Semicon-Optronics Channel Corp.
Street : 9F, No.563, Sec. 1, Beising Rd., Jhudong,
Town : Hsinchu, 31042,
Country : Taiwan
Telephone : ./.
Fax : ./.

Test item

Description of test item

Type of Product : High Power LED Driver

Type identification : HPD004B

Power supply : Input: 10-24 V AC/DC, 60/50 Hz ; Output: 2-24 V AC/DC, 0.8 A

Multi-listing Model number : HPD Series

Test Standards

EN 55015 (2000+A1 :2001+A2 :2002),

EN 61547 (1995+A1 :2000), (IEC/EN61000-4-2 (1995+A1:1998+A2: 2001)/-3 (2006))

Special statement: The standards applied to this test sample were under the demand of the applicant. Any deviation from the applicable product standards is the responsibility of the applicant.

Electro - Magnetic Compatibility

Test – Result

Device : High Power LED Driver
Model No : HPD004B
Manufacturer : Semicon-Optronics Channel Corp.
 9F, No.563, Sec. 1, Beising Rd., Jhudong, Hsinchu, 31042, Taiwan

1st test test after modification production test

Test Emission / Immunity			Done	Test passed	Test failed
Emission	Radiated electromagnetic Emission	EN 55015 (2000+A1 :2001+A2 :2002)	<input checked="" type="checkbox"/>	<input checked="" type="checkbox"/>	<input type="checkbox"/>
ESD	Electrostatic Discharge	IEC/EN 61000 - 4 - 2 (1995+A1:1998+A2: 2001)	<input checked="" type="checkbox"/>	<input checked="" type="checkbox"/>	<input type="checkbox"/>
RF - Field	Radiated Immunity	IEC/EN 61000 - 4 - 3 (2006)	<input checked="" type="checkbox"/>	<input checked="" type="checkbox"/>	<input type="checkbox"/>

Technical responsibility for area of testing:

Steven Chuang

Issue Date : August 20, 2007

Tester:

Jay Chaing

August 20, 2007

Note:

1. The result of this test report is valid only in connection to the sample has been tested at the laboratory of ETS Product Service (Taiwan) Co., Ltd.
2. This test report shall always be duplicated in full pages unless the written approval of the testing laboratory is obtained.

Test equipment utilized

No.	Test equipment	Type	Serial No.	Manufacturer	Cal. Date	Next Cal. Date
ETSTW-CE 001	EMI TEST RECEIVER	ESHS10	842121/013	R&S	2006/10/16	2007/10/15
ETSTW-CE 002	PREREULATOR MODE DC POWER SUPPLY	None	None		Function Test	
ETSTW-CE 003	AC POWER SOURCE	APS-9102	D161137	GW	Function Test	
ETSTW-CE 004	ZWEILEITER-V-NETZNACHBILDUNG TWO-LINE V-NETWORK	ESH3-Z5	840731/011	R&S	2006/10/16	2007/10/15
ETSTW-CE 005	Line-Impedance Stabilisation Network	NNBM 8126D	137	Schwarzbeck	2006/10/16	2007/10/15
ETSTW-CE 006	IMPULSBEGRENZER PULSE LIMITER	ESH3-Z2	100226	R&S	In House Certificate	
ETSTW-CE 008	ABSORBING CLAMP	MDS 21	3469	Schwarzbeck	2005/10/24	2007/10/23
ETSTW-CE 009	TEMP.&HUMIDITY CHAMBER	GTH-225-40-1P-U	MAA0305-009	GIANT FORCE	2007/8/2	2008/8/1
ETSTW-CE 013	CISPR 22 TWO BALANCED TELECOM PAIRS IMPEDANCE STABILIZATION NETWORK	FCC-TLISN-T4-02	20242	FCC	2005/12/8	2007/12/7
ETSTW-CE 014	CISPR 22 TWO BALANCED TELECOM PAIRS IMPEDANCE STABILIZATION NETWORK	FCC-TLISN-T2-02	20241	FCC	2005/12/7	2007/12/6
ETSTW-CE 015	CISPR 22 TWO BALANCED TELECOM PAIRS IMPEDANCE STABILIZATION NETWORK	FCC-TLISN-T8-02	20307	FCC	2006/11/7	2008/11/6
ETSTW-CE 016	TWO-LINE V-NETWORK	ENV216	100050	R&S	2006/11/21	2007/11/20
ETSTW-CS 003	COUPLING AND DECOUPLING NETWORK	CDN T400	19820	SCHAFFNER	2005/10/14	2007/10/13
ETSTW-CS 004	COUPLING AND DECOUPLING NETWORK	CDN M016	20053	SCHAFFNER	2006/10/11	2007/10/10
ETSTW-CS 005	RF Power Amplifier	100A250A	306547	AR	2006/10/11	2007/10/10
ETSTW-CS 008	6 dB Attenuator	HFP-5100-3/06 N M/F	2010876106		In House Certificate	
ETSTW-RE 002	Function Generator	33220A	MY43004982	Agilent	2005/10/14	2007/10/13
ETSTW-RE 003	EMI TEST RECEIVER	ESI 26	831438/001	R&S	2006/10/20	2007/10/19
ETSTW-RE 004	EMI TEST RECEIVER	ESI 40	832427/004	R&S	2006/10/30	2007/10/29
ETSTW-RE 005	EMI TEST RECEIVER	ESVS10	843207/020	R&S	2006/10/12	2007/10/11
ETSTW-RE 010	PROGRAMMABLE LINEAR POWER SUPPLY	LPS-305	30503070181	MOTECH	Function Test	
ETSTW-RE 011	PROGRAMMABLE LINEAR POWER SUPPLY	LPS-305	30503070165	MOTECH	Function Test	
ETSTW-RE 017	Log-Periodic Antenna	HL025	352886/001	R&S	2006/5/4	2008/5/3
ETSTW-RE 018	MICROWAVE HORN ANTENNA	AT4560	27212	AR	2004/11/8	2007/11/7
ETSTW-RE 020	MICROWAVE HORN ANTENNA	AT4002A	306915	AR	Function Test	
ETSTW-RE 021	SWEEP GENERATOR	SWM05	835130/010	R&S	2006/10/11	2007/10/10
ETSTW-RE 027	Passive Loop Antenna	6512	00034563	EMCO	In House Certificate	
ETSTW-RE 028	Log-Periodic Dipole Array Antenna	3148	34429	EMCO	2006/5/26	2008/5/25
ETSTW-RE 029	Biconical Antenna	3109	33524	EMCO	2006/5/26	2008/5/25
ETSTW-RE 030	Double-Ridged Guide Horn Antenna	3117	00035224	EMCO	2006/5/3	2008/5/2
ETSTW-RE 032	Millivoltmeter	URV 55	849086/013	R&S	2006/10/11	2007/10/10

Registration number: W6M20707-8262-E-11

ETSTW-RE 034	Power Sensor	URV5-Z4	839313/006	R&S	2005/10/17	2007/10/16
ETSTW-RE 042	Biconical Antenna	HK116	100172	R&S	2007/1/11	2009/1/10
ETSTW-RE 043	Log-Periodic Dipole Antenna	HL223	100166	R&S	2006/5/8	2008/5/7
ETSTW-RE 044	Log-Periodic Antenna	HL050	100094	R&S	2006/5/29	2008/5/28
ETSTW-RE 048	Triple Loop Antenna	HXYZ 9170	HXYZ 9170-134	Schwarzbeck	2005/3/22	2008/3/21
ETSTW-RE 049	TRILOG Super Broadband test Antenna	VULB 9160	9160-3185	Schwarzbeck	2007/5/2	2009/5/1
ETSTW-RE 055	SPECTRUM ANALYZER	FSU-26	200074	R&S	2007/7/16	2008/7/15
ETSTW-RE 064	Bluetooth Test Set	MT8852B-042	6K00005709	Anritsu	Function Test	
ETSTW-RE 072	CELL SITE TEST SET	8921A	3339A00375	HP	2007/7/2	2009/7/1
ETSTW-EMI 001	HARMONICS 1000	HAR 1000-1P	093	EMC-PARTNER	2006/9/12	2007/9/11
ETSTW-EMS 001	BASELSTRASSE 160 CH-4242 LAUFEN	CN-EFT1000	354	EMC-PARTNER	2004/11/2	2007/11/1
ETSTW-EMS 002	Frequency Converter	YF-6020	308014	T-Power	Function Test	
ETSTW-EMS 003	EMC Immunity Test System	TRA2000IN6	579	EMC-PARTNER	2006/11/8	2007/11/7
ETSTW-EMS 004	ESD Simulator	ESD2000	16	EMC-PARTNER	2006/10/18	2007/10/17
ETSTW-EMS 008	Safety Test Solutions	ELT-400	E-0039	Narda	2005/5/4	2008/5/3
ETSTW-EMS 009	Magnetic Field Antenna	MF1000-1	104	EMC-PARTNER	2004/12/3	2007/12/2
ETSTW-EMS 010	Coupling De-coupling Network	CDN-UTP8	14	EMC-PARTNER	2005/9/1	2008/8/31
ETSTW-EMS 011	Calibration Fixture	F-2031-CF-23MM	451	FCC	2006/7/29	2008/7/28
ETSTW-EMS 012	EM Injection Clamp	F-2031-23MM	476	FCC	2006/7/29	2008/7/28
ETSTW-EMS 014	Digital Thermo-Hygro Meter	0507	02	WISEWIND	2005/11/15	2007/11/14
ETSTW-RS 003	RF Power Amplifier	30S1G3	306933	AR	2006/10/11	2007/10/10
ETSTW-RS 004	RF Power Amplifier	150W1000	307009	AR	2006/10/11	2007/10/10
ETSTW-RS 005	Electric Field Probe Type 8.3	2244/90.21	AF-0016	Narda	2005/9/7	2007/9/6
ETSTW-RS 006	SIGNAL GENERATOR	SML03	101551	R&S	2006/10/9	2007/10/8
ETSTW-RS 007	14" COLOR VIDEO MONITOR	HS-CM145A	0512011548		Function Test	

Registration number: W6M20707-8262-E-11

Radiated electromagnetic Emission

Test Equipment

a) Triple Loop Antenna

For your reference please find it in our test equipment list at page 3 to 4 as number : ETSTW-RE 048

b) SPECTRUM ANALYZER

For your reference please find it in our test equipment list at page 3 to 4 as number : ETSTW-RE 055

Test Procedures

- Test configuration

The test configuration corresponds to the standard CISPR 15. The lighting equipment under test is placed in the centre of the antenna. (see picture 1)

In the case of lighting equipment incorporating more than one lamp, all the lamps are operated simultaneously. The earth terminal of the lighting equipment shall be connected to the reference earth of the V-network. The observation of the equipment under test is realized by 3 video cameras and by a microphone.

- Test parameter and marginal conditions

The test are carried out with a frequency range between 9 kHz to 30 MHz. Further information please find in test report.

Radiated electromagnetic emission acc. EN 55015

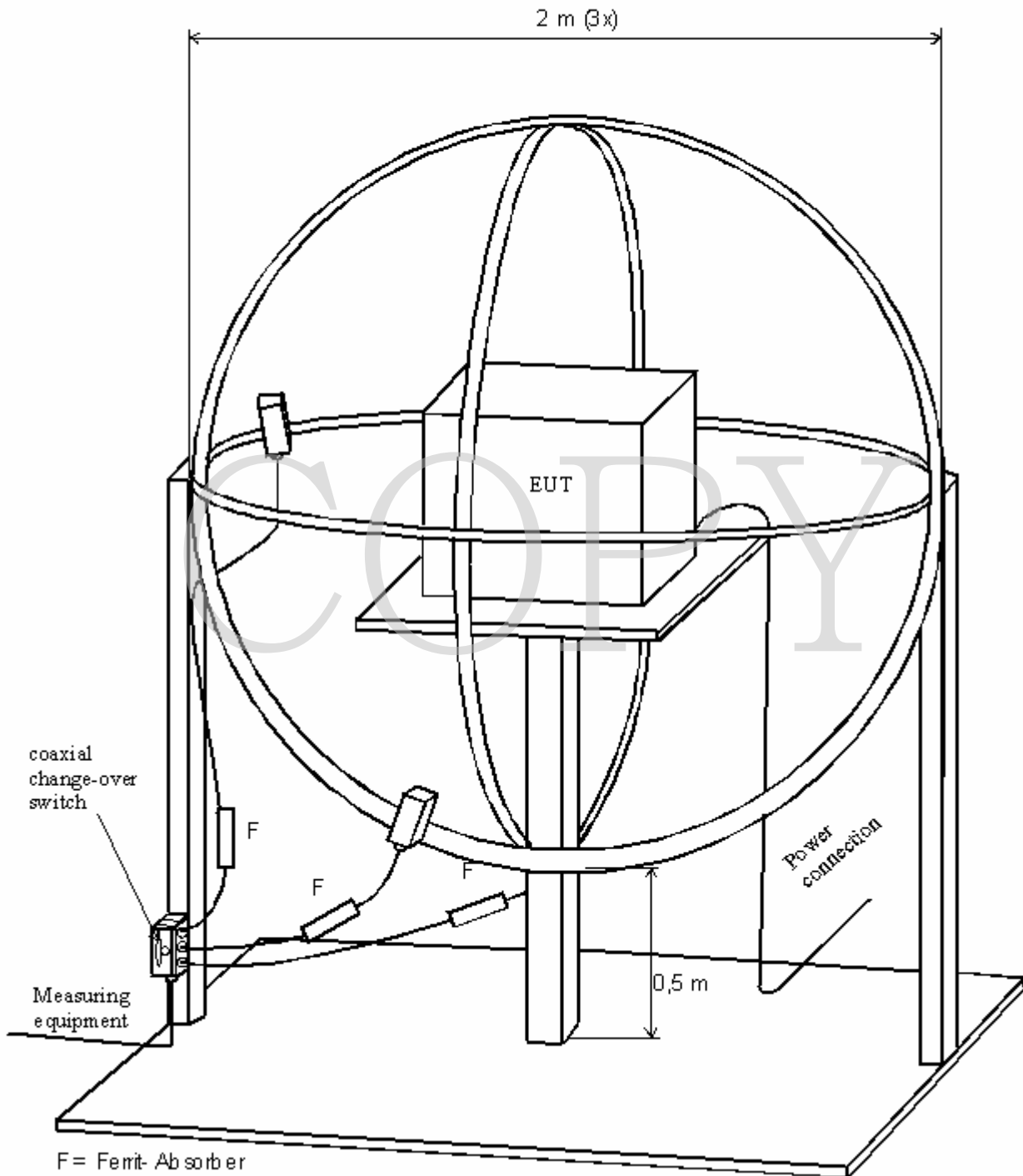

Picture 1

Registration number: W6M20707-8262-E-11

Electrostatic Discharge

Test Equipment

a) ESD Simulator (ESD2000)

For your reference please find it in our test equipment list at page 3 to 4 as number : ETSTW-EMS 004

b) EMC Immunity Test System (TRA2000IN6)

For your reference please find it in our test equipment list at page 3 to 4 as number : ETSTW-EMS 003

c) Frequency Converter (YF-6020)

For your reference please find it in our test equipment list at page 3 to 4 as number : ETSTW-EMS 002

Test Procedures

- Test configuration

The test configuration is in correspondence to the standard IEC/EN 61000-4-2. The equipment under test is placed on a wooden table with one metal plate on its top and one metal plate under the table, which is grounded. Both plates are connected with two 470 k Ω resistor in series. (see picture 2)

- Test parameters and marginal conditions

The test is carried out with $\pm 2\text{kV}$, $\pm 4\text{kV}$ contact discharge and $\pm 2\text{kV}$, $\pm 4\text{kV}$ and $\pm 8\text{kV}$ air discharge.

Time between two discharges ≥ 1 second

Ten discharges for every point every voltage and polarity

The tested points please find in the test protocol.

Electrostatic Discharge according to EN 61000 - 4 - 2

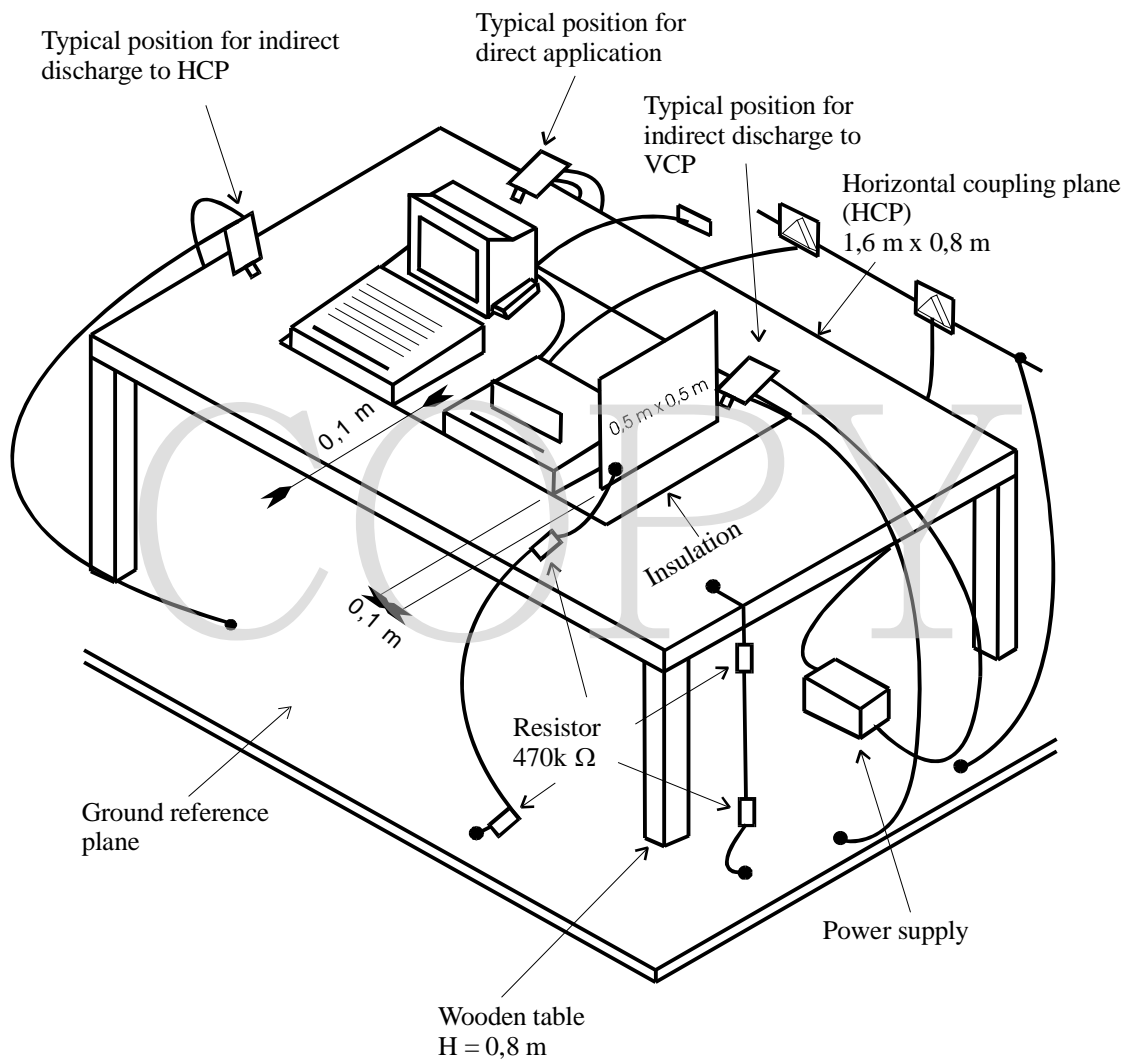

Picture 2

Registration number: W6M20707-8262-E-11

RF Electromagnetic Field (80-1000 MHz)

Test Equipment

- a) Biconical Antenna (3109)
For your reference please find it in our test equipment list at page 3 to 4 as number: ETSTW-RE 029
- b) Log-Periodic Dipole Antenna (HL223)
For your reference please find it in our test equipment list at page 3 to 4 as number: ETSTW-RE 043
- c) MICROWAVE HORN ANTENNA (AT4560)
For your reference please find it in our test equipment list at page 3 to 4 as number: ETSTW-RE 018
- d) Biconical Antenna (HK116)
For your reference please find it in our test equipment list at page 3 to 4 as number: ETSTW-RE 042
- e) SIGNAL GENERATOR (SML03)
For your reference please find it in our test equipment list at page 3 to 4 as number: ETSTW-RS 006
- f) RF Power Amplifier (150W1000)
For your reference please find it in our test equipment list at page 3 to 4 as number: ETSTW-RS 004
- g) Electric Field Probe Type 8.3 (EMR-20)
For your reference please find it in our test equipment list at page 3 to 4 as number: ETSTW-RS 005
- h) Millivoltmeter (URV 55)
For your reference please find it in our test equipment list at page 3 to 4 as number: ETSTW-RE 032
- i) Power Sensor (URV5-Z4)
For your reference please find it in our test equipment list at page 3 to 4 as number: ETSTW-RE 034

Test Procedures

- Test configuration

The test configuration is contained inside of a shielded chamber and corresponds to the standard IEC/EN 61000-4-3. The equipment under test is placed in the facility on a wooden table 0.8m high on the center axis of the chamber. The power supply and the RF connection points are close to the equipment under test at the floor of the chamber inside a connection box. The cables to this connection box are shielded and below the double floor. The transmitting antenna is placed in a height of 1.5m, in a distance of 3.0m. The RF-generators are placed in a special room adjacent to the chamber. (see picture 3) The observation of the equipment under test is realized by 3 video cameras and by a microphone. In order to establish the severity of the test for EUTs an wires which must be tested close to the earth reference plane or which have larger sides than 1,5m x 1,5 m, the intensity of the field is also recorded at 0,4 m height, and for the full width and height of the EUT.

- Test parameters and marginal conditions

The tests are carried out with a field strength by 3 V/m (measured in the unmodulated field) with amplitude modulated signal by a depth of 80 % by a sinusoidal audio signal of 1 kHz. The logarithmic step was 1% and the dwell time was 1s dependent of the EUT cycle time. Further information please find in test protocol.

RF - Field according to EN 61000 - 4 - 3

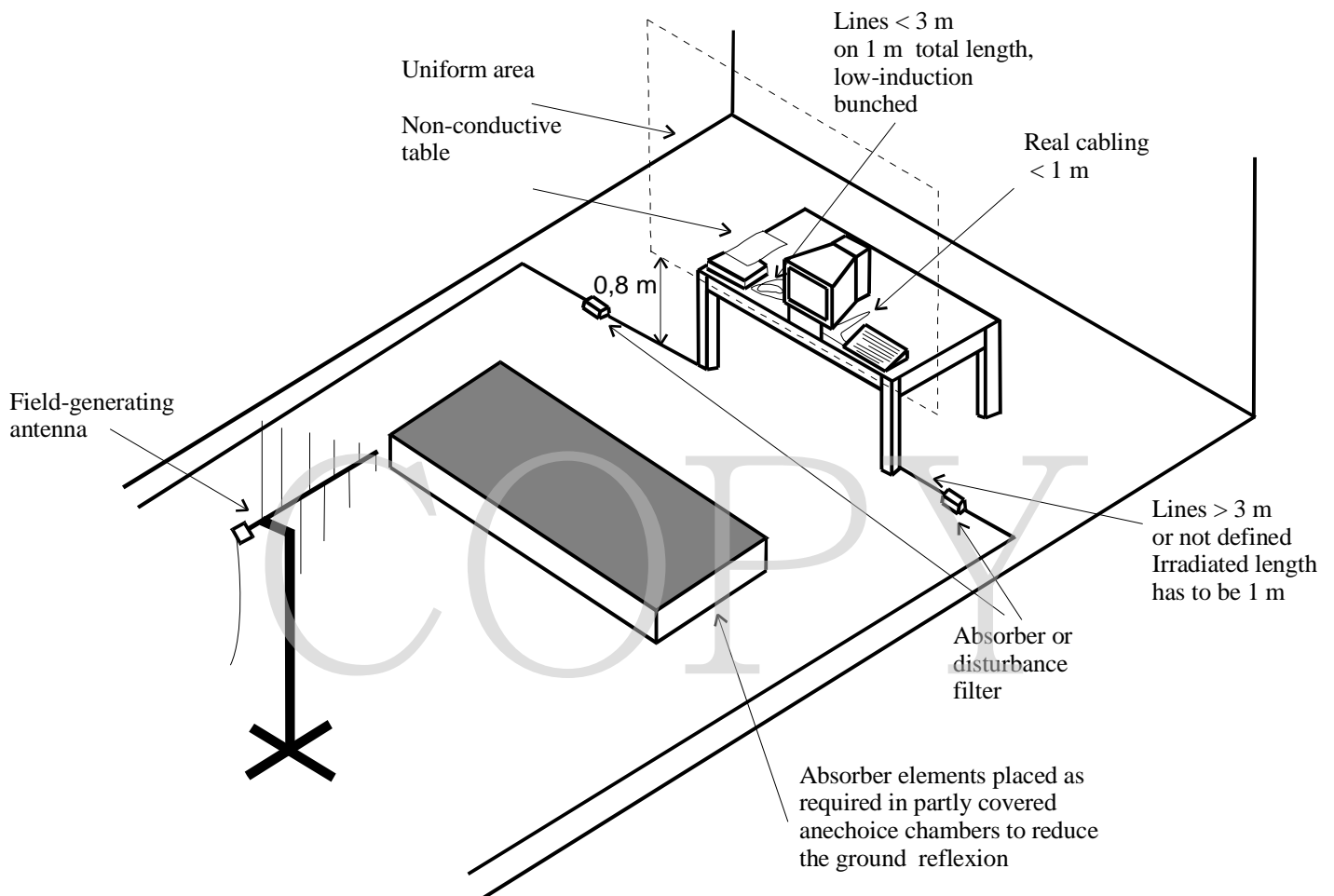

Picture 3

Registration number: W6M20707-8262-E-11

Radiated electromagnetic Emission

Emission

Standard : EN 55015

Device : HPD004B

Date : July 05, 2007

Temperature : 23.9 °C

Pressure : 921 hPa

Rel. humidity: 52 %

X axis

Frequency Marker (MHz)	Reading (dBuV)	Correction Factor (dB)	Detector	Test Result (dBuA)	Compliance Limit (dBuA)	Margin (dB)
0.011979	8.95	1	PK	9.95	88	78.05
0.027172	11.75	1	PK	12.75	88	75.25
1.021539	5.9	1	PK	6.90	35	28.10
1.257723	3.9	1	PK	4.90	32	27.10

Y axis

Frequency Marker [MHz]	Reading [dBuV]	Correction Factor (dB)	Detector	Test Result (dBuA)	Compliance Limit [dBuA]	Margin (dB)
0.119598	11.26	1	PK	12.26	35	22.74
0.656603	9.58	1	PK	10.58	65	54.42
0.995322	21.99	1	PK	22.99	32	9.01
1.257723	14.65	1	PK	15.65	40.5	24.85

Registration number: W6M20707-8262-E-11

Z axis

Frequency Marker [MHz]	Reading [dBUV]	Correction Factor (dB)	Detector	Test Result (dBUA)	Compliance Limit [dBUA]	Margin (dB)
0.017239	11.75	1	PK	12.75	37	24.25
0.027527	11.75	1	PK	12.75	32	19.25
0.995322	18.37	1	PK	19.37	88	68.63
1.257723	11.10	1	PK	12.10	58	45.90

- Note**
1. The formula of measured value as: **Test Result = Reading + Correction Factor**
 2. **The Correction Factor = Cable loss + Antenna factor+ Switch Insertion Loss**
 3. **Detector function in the form: PK = Peak, QP = Quasi Peak, AV = Average**
 4. **All not in the table noted test results are more than 20 dB below the relevant limits.**
 5. **dBUV Convertor dBUA 1: 1.**
 6. **See attached diagram as appendix**

COPY

Electrostatic Discharge

ESD

Standard : IEC/EN 61000 - 4 - 2

Device : HPD004B

Date : July 05, 2007

Temperature : 24.8 °C
Pressure : 990 hPa
Rel. humidity: 50 %

Test point	Table (T) Floor (F)	Contact (C) Air (A)	Voltage (kV)	Polarity (+/-)	Note
Housing	T	A	2, 4, 8	+/-	A
Housing	T	C	2, 4	+/-	A
Indirect	T	C	2, 4	+/-	A

Registration number: W6M20707-8262-E-11

ESD discharge points

The top of EUT

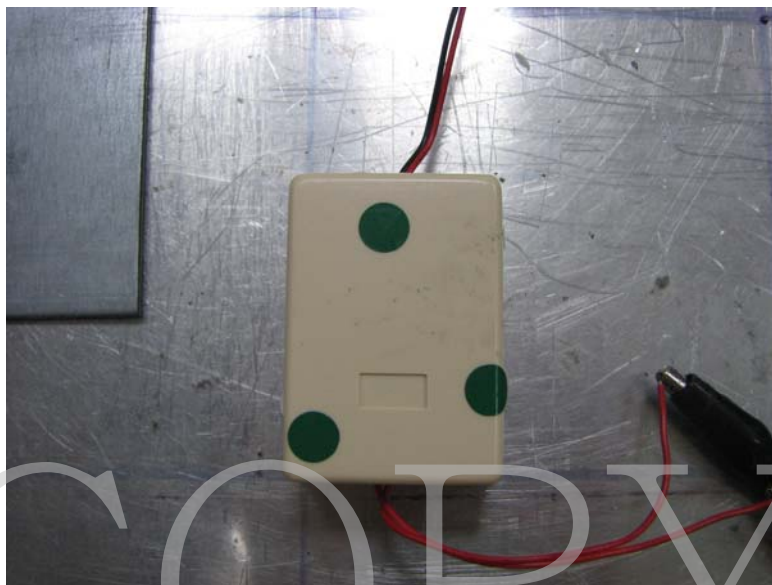

The bottom of EUT

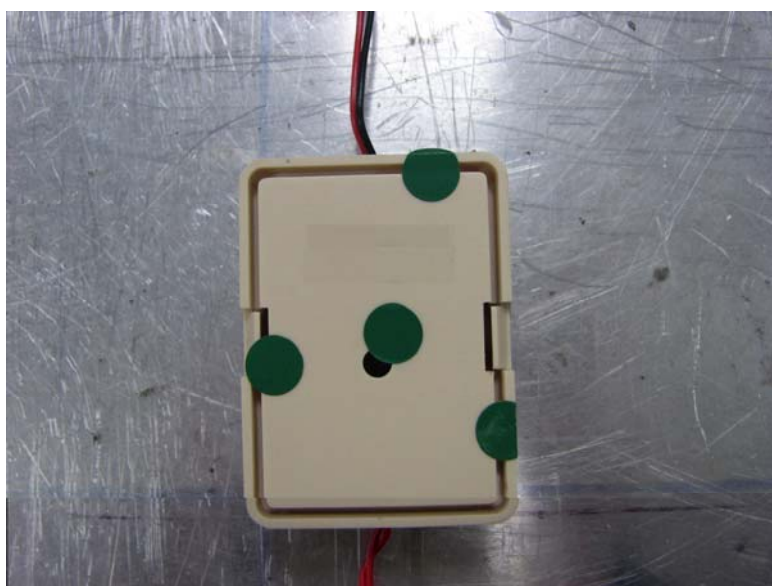

The front of EUT

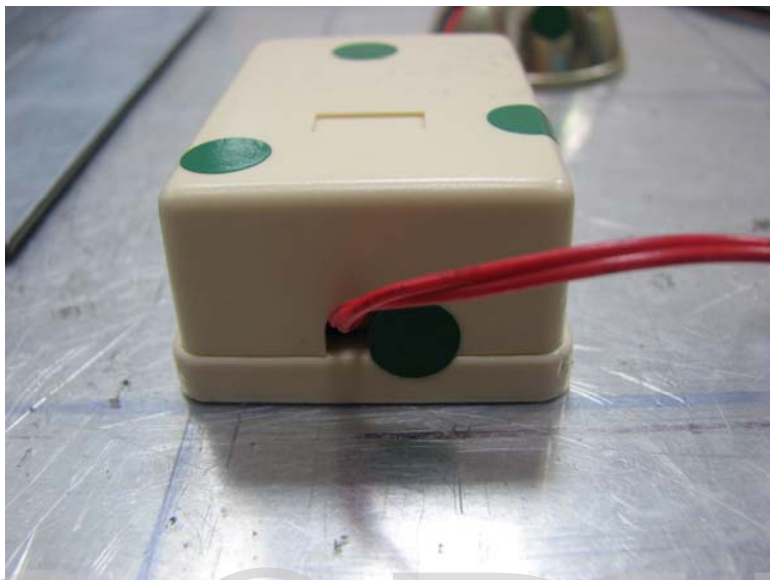

The back of EUT

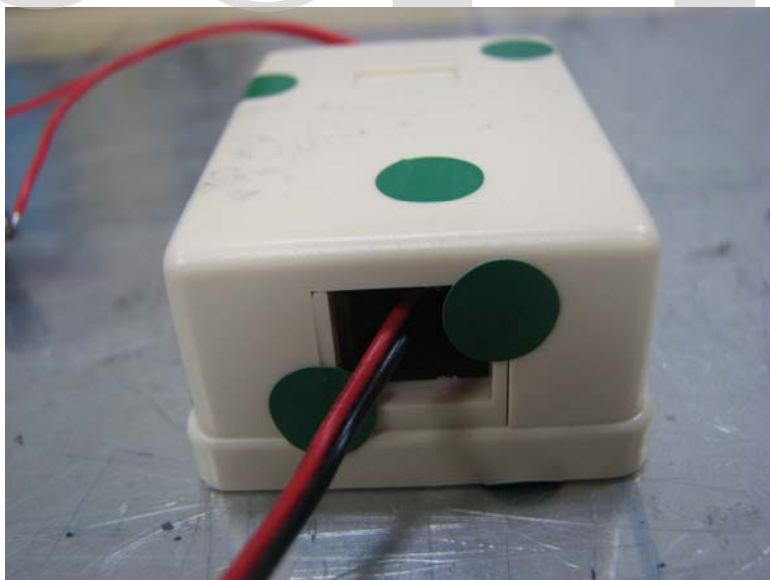

Registration number: W6M20707-8262-E-11

The left of EUT

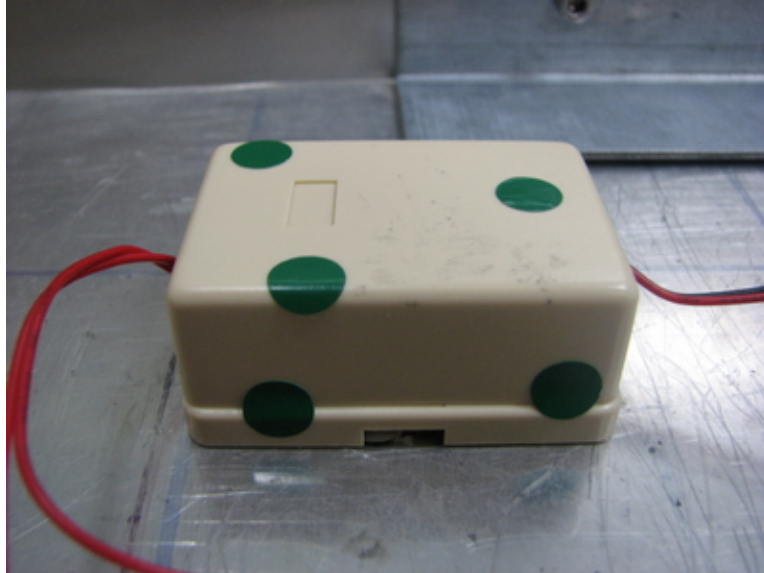

The right of EUT

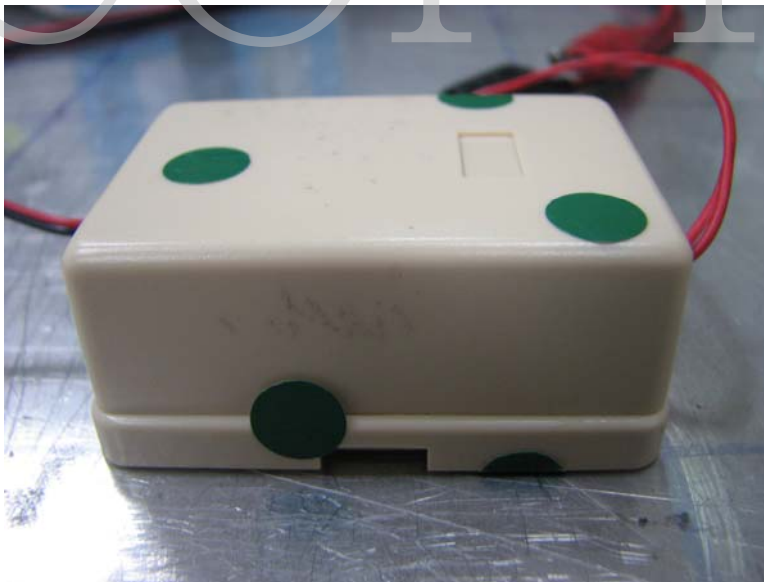

Registration number: W6M20707-8262-E-11

Note:

- A: Normal performance within the specification.
- B: Temporary degradation or less of function or performance which is self recoverable
- C: Temporary degradation or loss of function or perform. which requires. operate intervention or system reset
- D: Degradation or loss of function which is not recoverable due to damage of equipment (components) or software, or loss of data.

NA: Not Applicable

Explanation: ./.

COPY

Interference Immunity Against Electromagnetic Irradiation

RF Field

Standard : IEC/EN 61000 - 4 - 3

Device : HPD004B

Date : July 05, 2007

Temperature : 24.8 °C
 Pressure : 990 hPa
 Rel. humidity: 50 %

Testequipment : Anechoic Chamber, Generator SMG (R&S), Monitoring System, Amplifier 10W1000/150L (ar), Antenna SAS-200/521 (AHS)

Severity Level : 2 (3 V/m) Modulation Frequency : 1kHz (80% AM)
Pulsmodulation : 1 Hz (0,5s on;0,5s off)

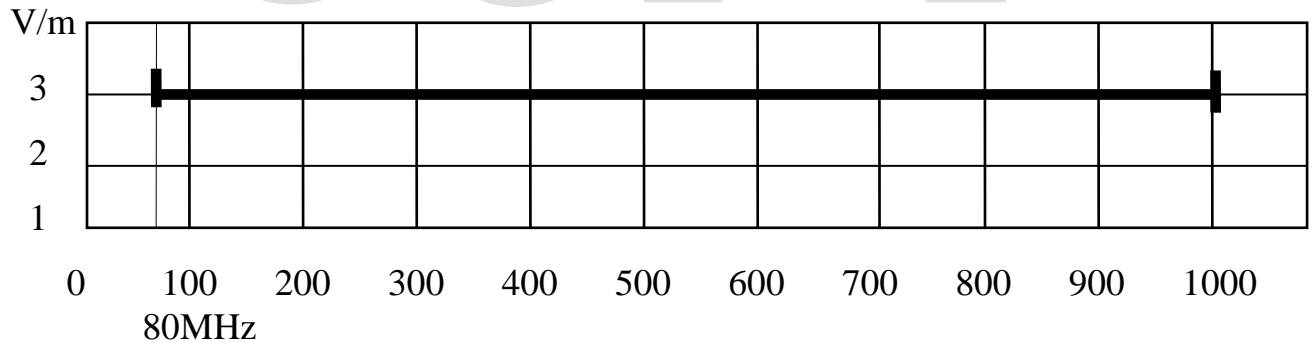

Note :

- A : No loss of performance or function
- B : Temporary loss of function or performance which is self recoverable
- C : Temporary loss of function or perform. which req. operate intervention or system reset
- D : Loss of function which is not recoverable

Registration number: W6M20707-8262-E-11

Appendix

A Measurement diagrams

Radiated electromagnetic Emission

(The measurement diagrams plots attached below are preliminary wideband scan with a peak detector and for reference only. The final test results are listed on page 11-12.)

B Photos

1. External Photos
2. Internal Photos
3. Set Up Photo of Radiated Emission
4. Set Up Photo of ESD
5. Set Up Photo of RF-Field

COPY

*Spurious emissions under normal conditions
in accordance to the EN 55015 / CNS 14115*

Order Number: W6M20707-8262
 Test Site / Operator: ETS / Catey
 Temperature/Voltage: Temp.: 23.9°C / Unom.: 24VDC
 Test Specification: Loop antenna
 Type: X mode

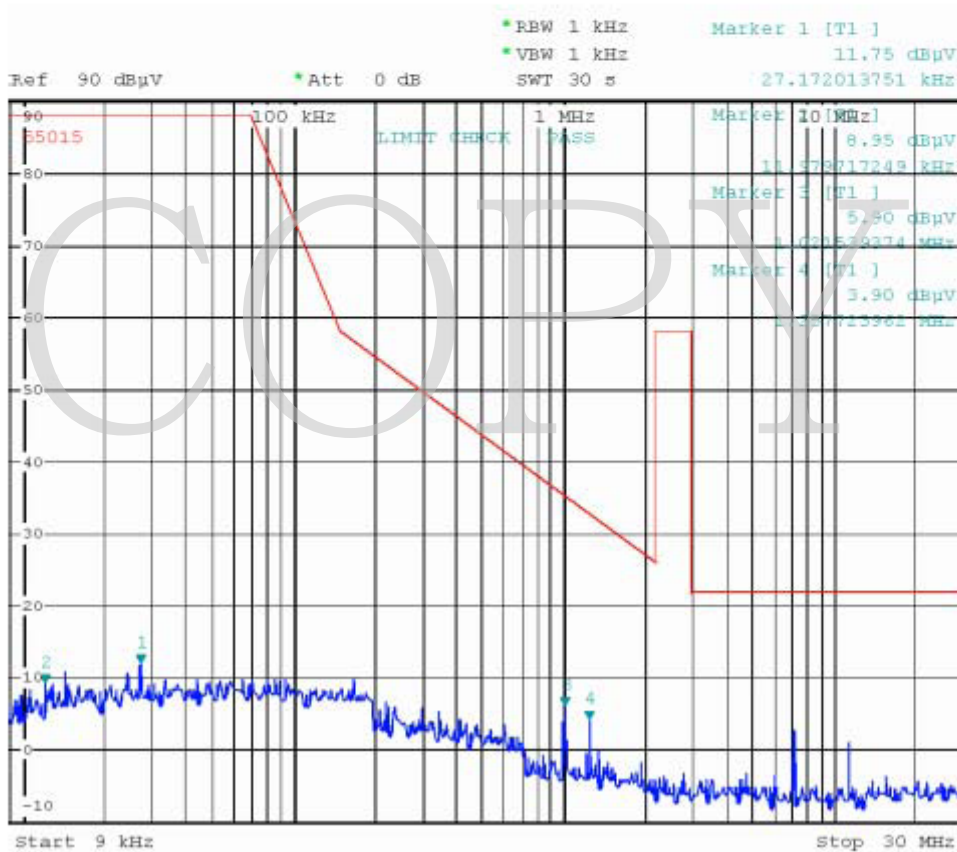

Registration number: W6M20707-8262-E-11

*Spurious emissions under normal conditions
in accordance to the EN 55015 / CNS 14115*

Order Number: W6M20707-8262
 Test Site / Operator: ETS / Catey
 Temperature/Voltage: Temp.: 23.9°C / Unom.: 24VDC
 Test Specification: Loop antenna
 Type: Y mode

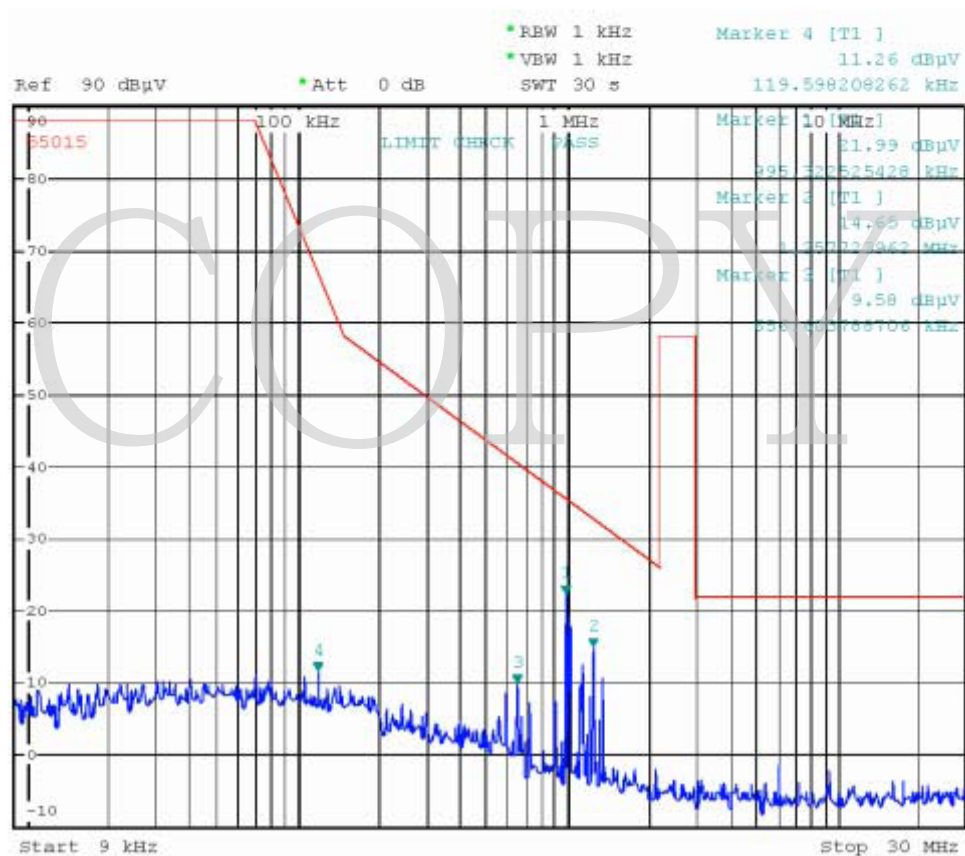

Registration number: W6M20707-8262-E-11

Spurious emissions under normal conditions in accordance to the EN 55015 / CNS 14115

Order Number: W6M20707-8262
 Test Site / Operator: ETS / Catey
 Temperature/Voltage: Temp.: 23.9°C / Unom.: 24VDC
 Test Specification: Loop antenna
 Type: Z mode

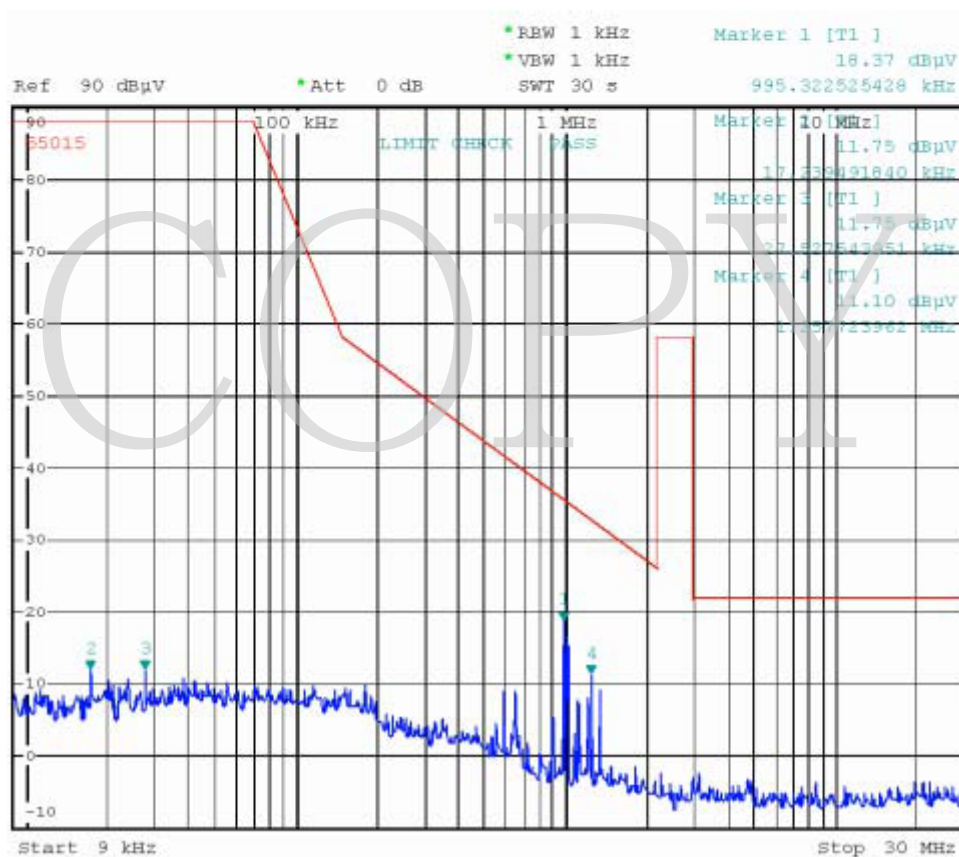

Registration number: W6M20707-8262-E-11

Pictures
External Photos

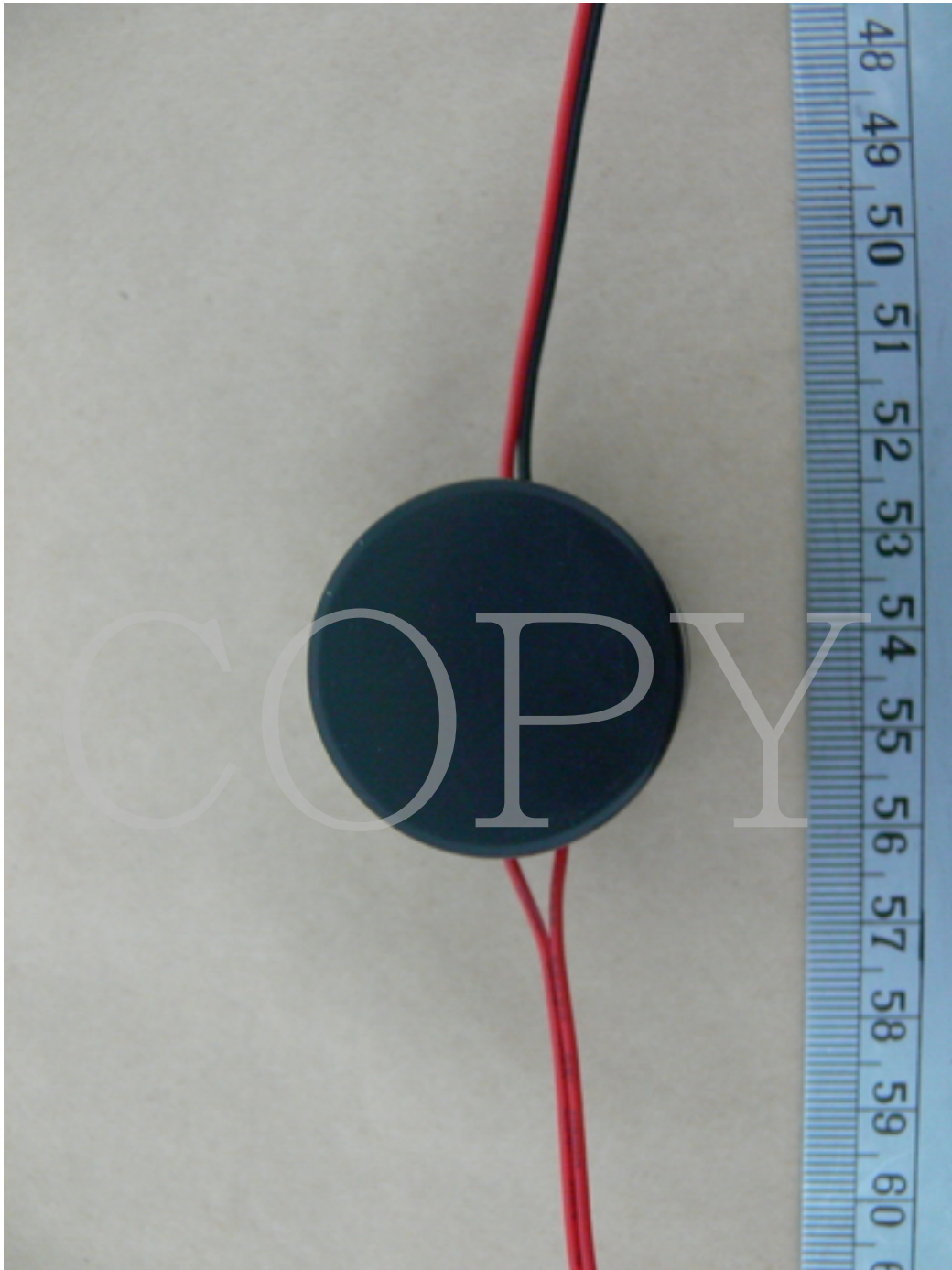

Registration number: W6M20707-8262-E-11



Registration number: W6M20707-8262-E-11



Registration number: W6M20707-8262-E-11

Internal Photos

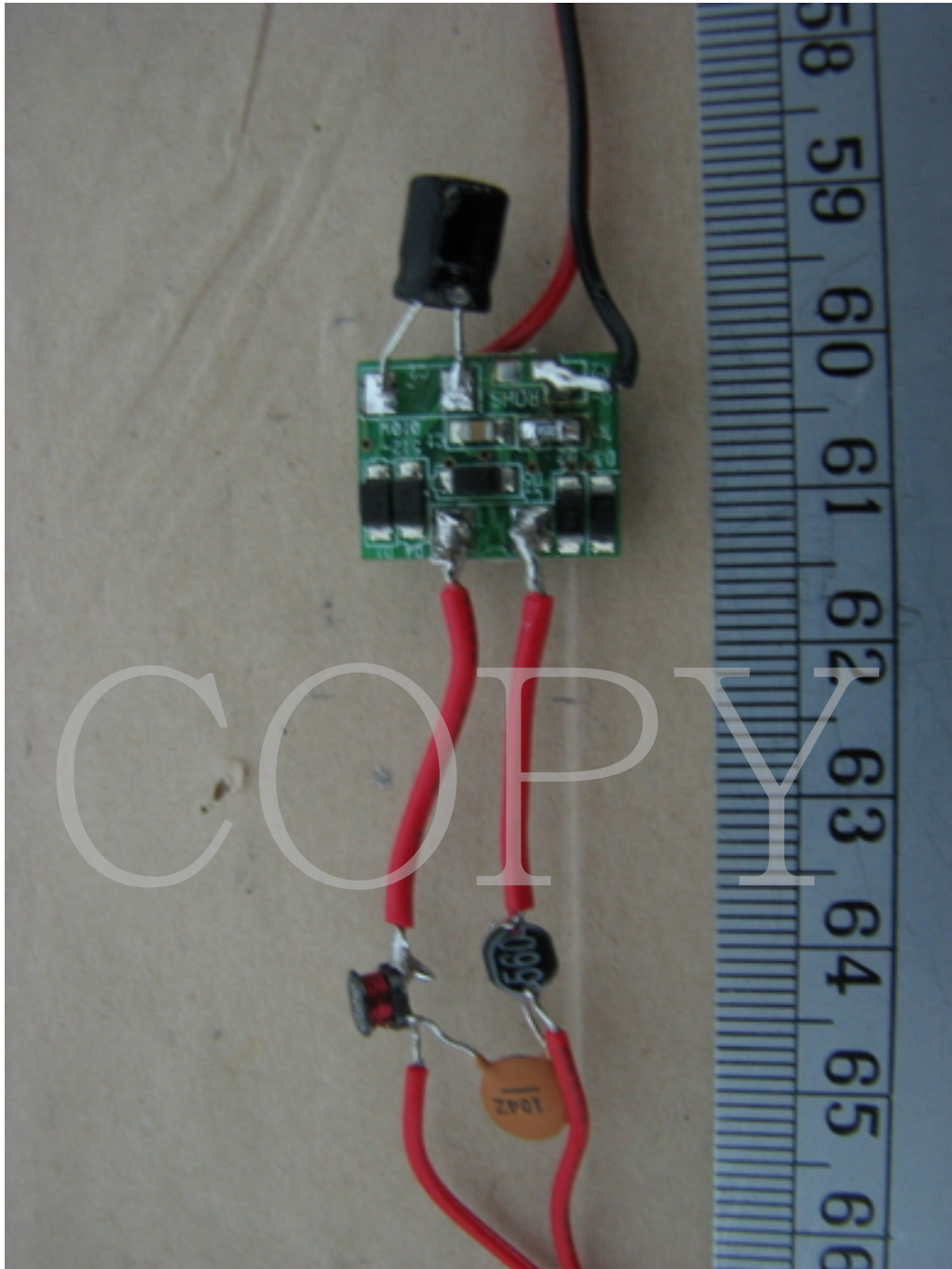

Registration number: W6M20707-8262-E-11

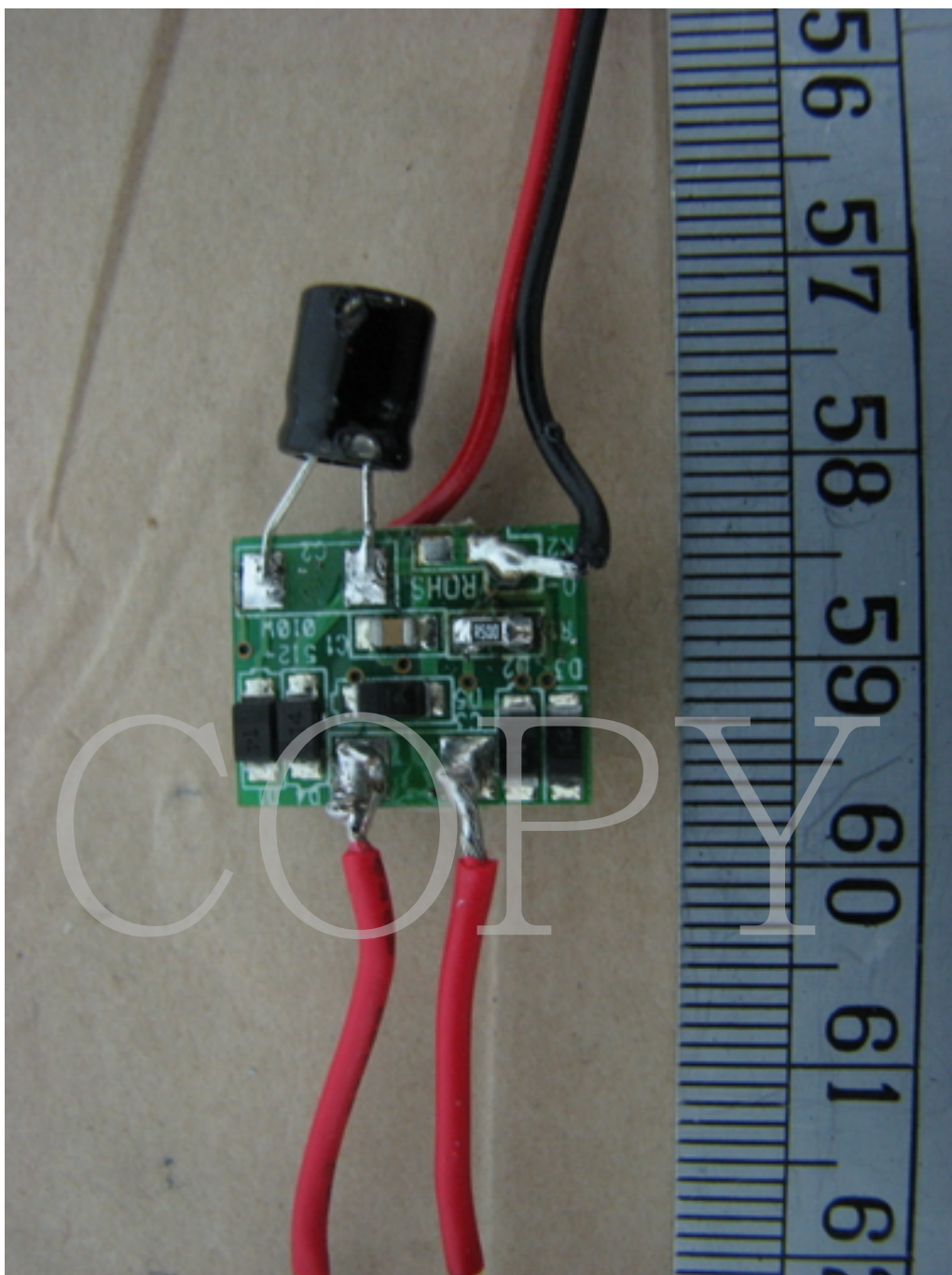

Registration number: W6M20707-8262-E-11

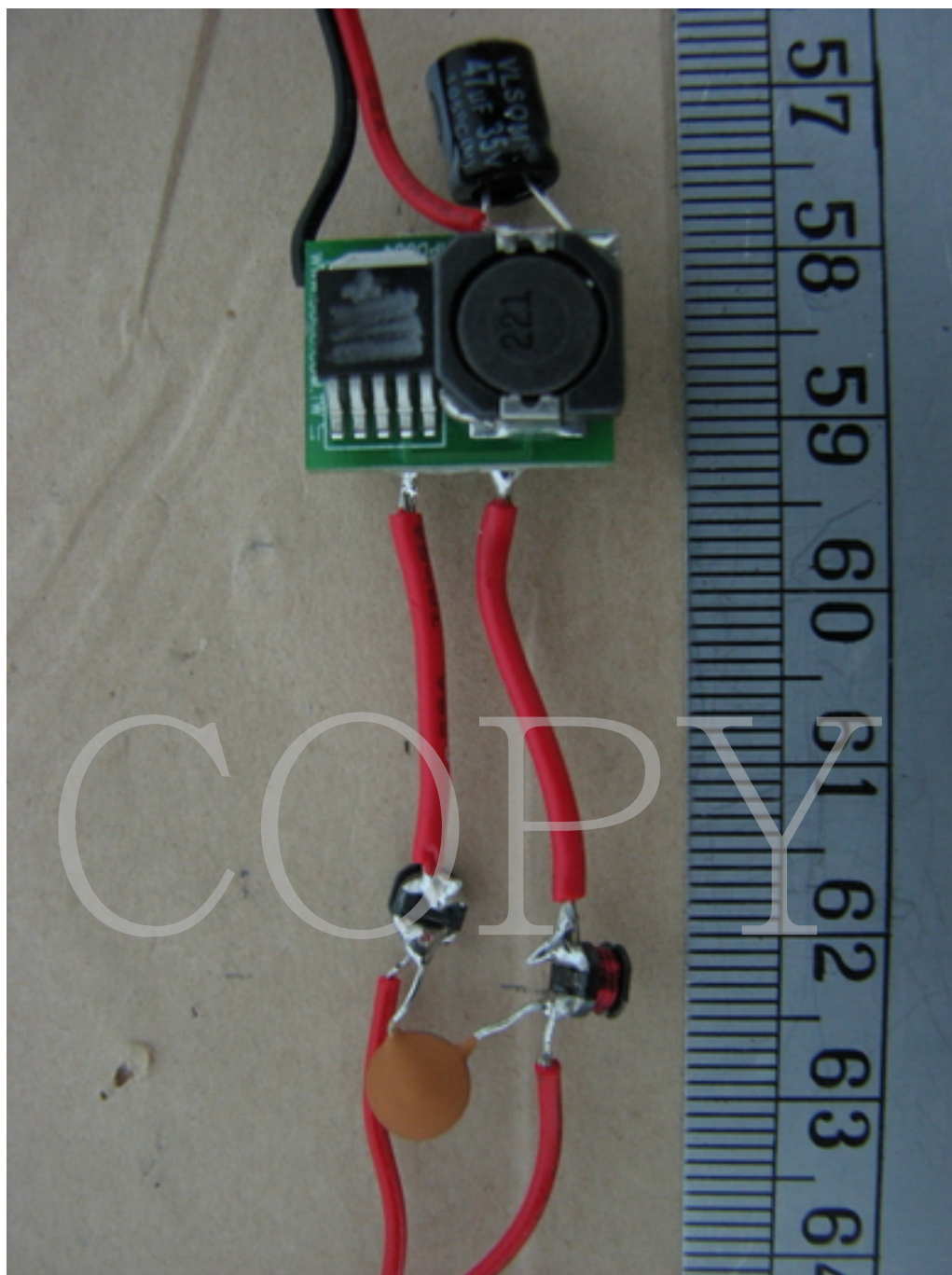

Registration number: W6M20707-8262-E-11

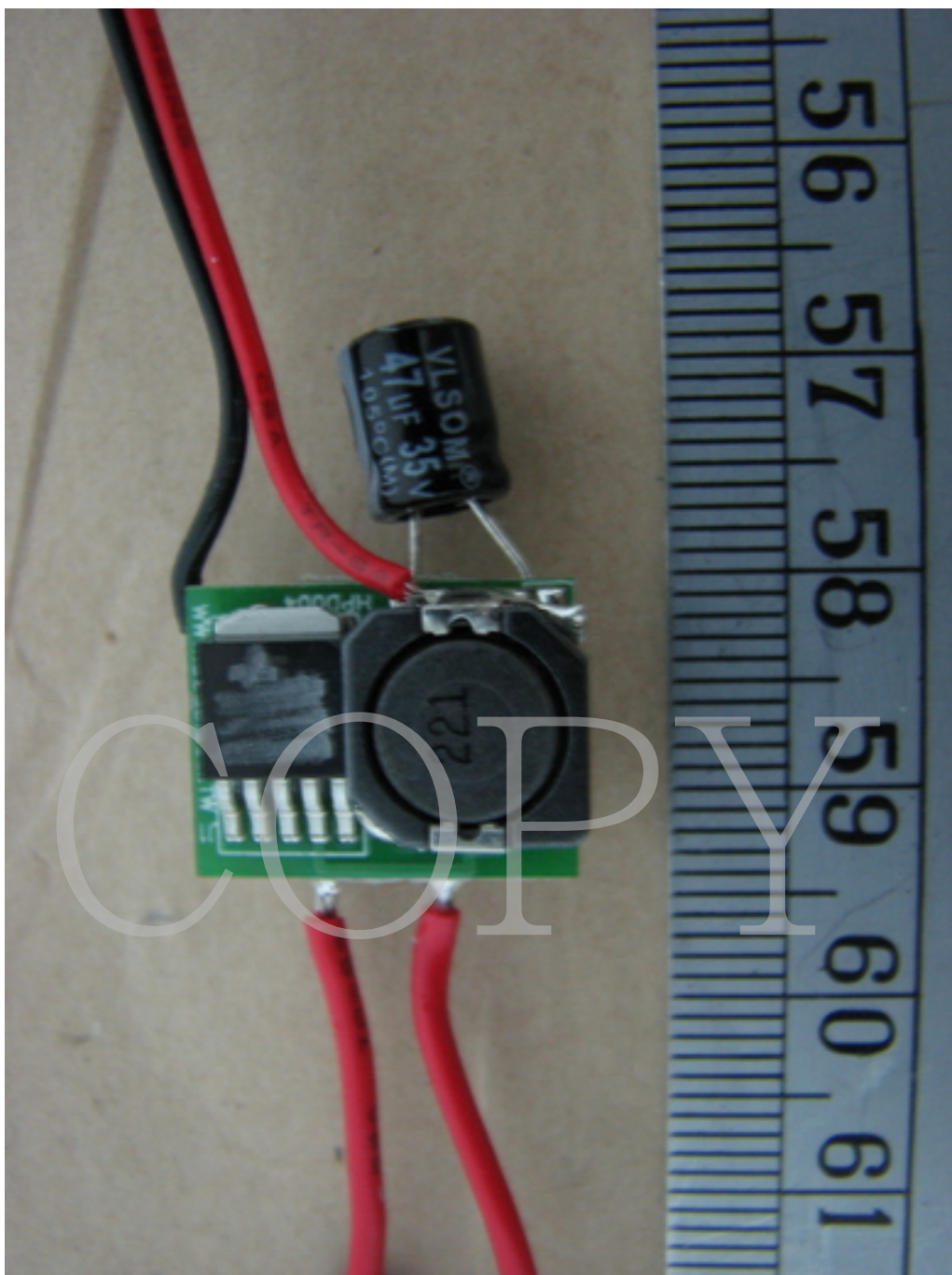

Registration number: W6M20707-8262-E-11

Set Up Photo of Radiated Emission

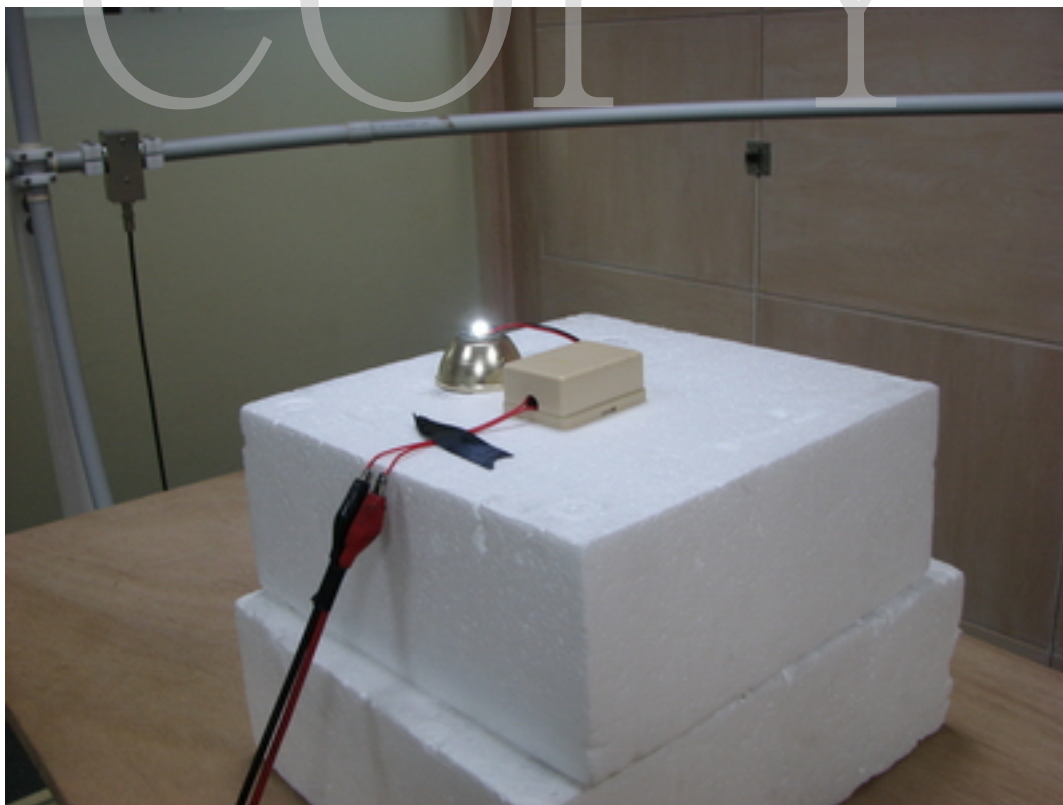
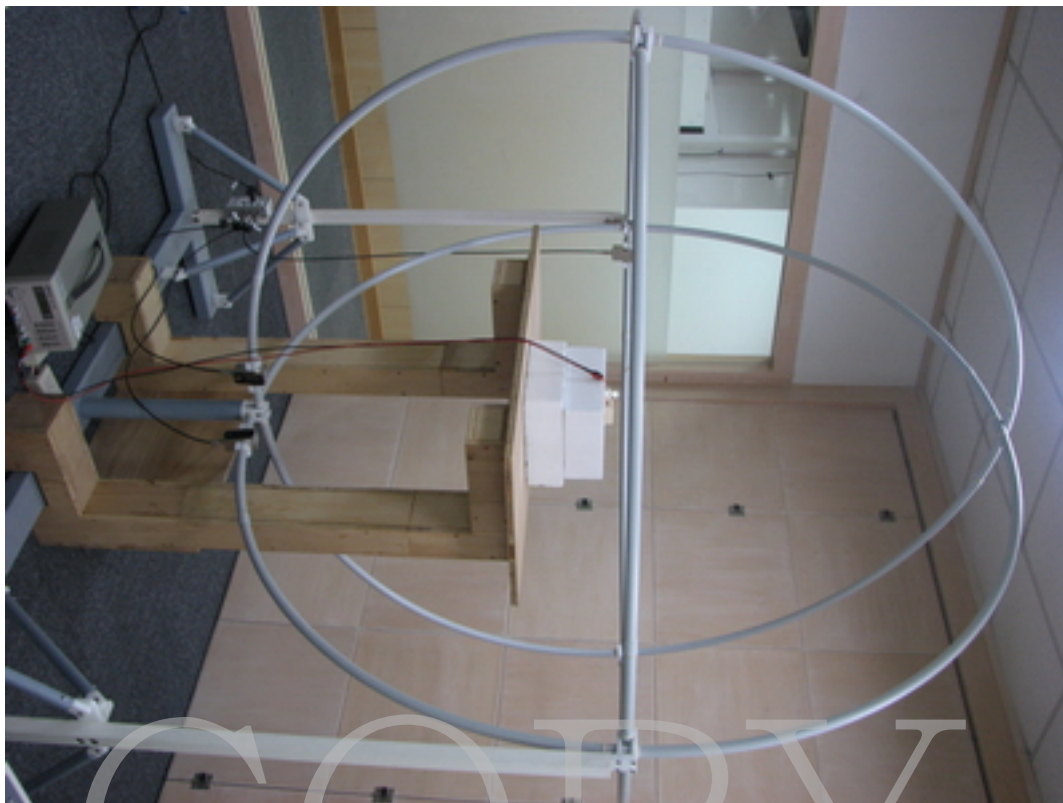

Registration number: W6M20707-8262-E-11

Set Up Photo of ESD

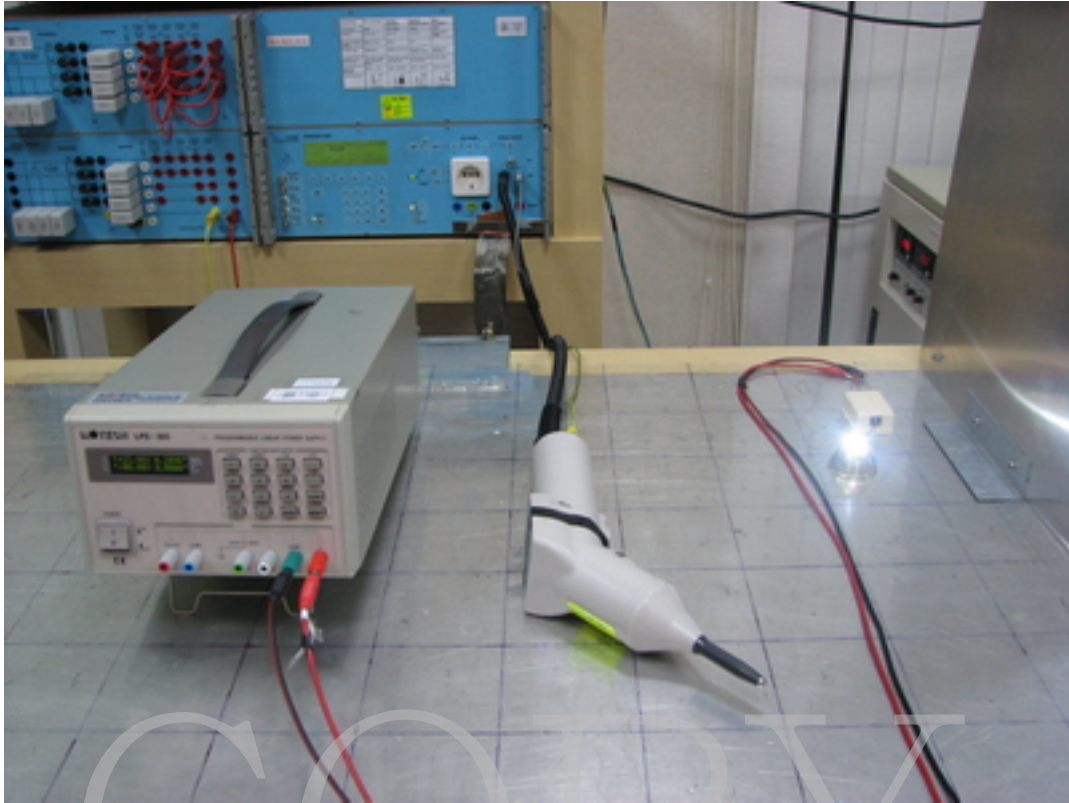

Set Up Photo of RF-Field

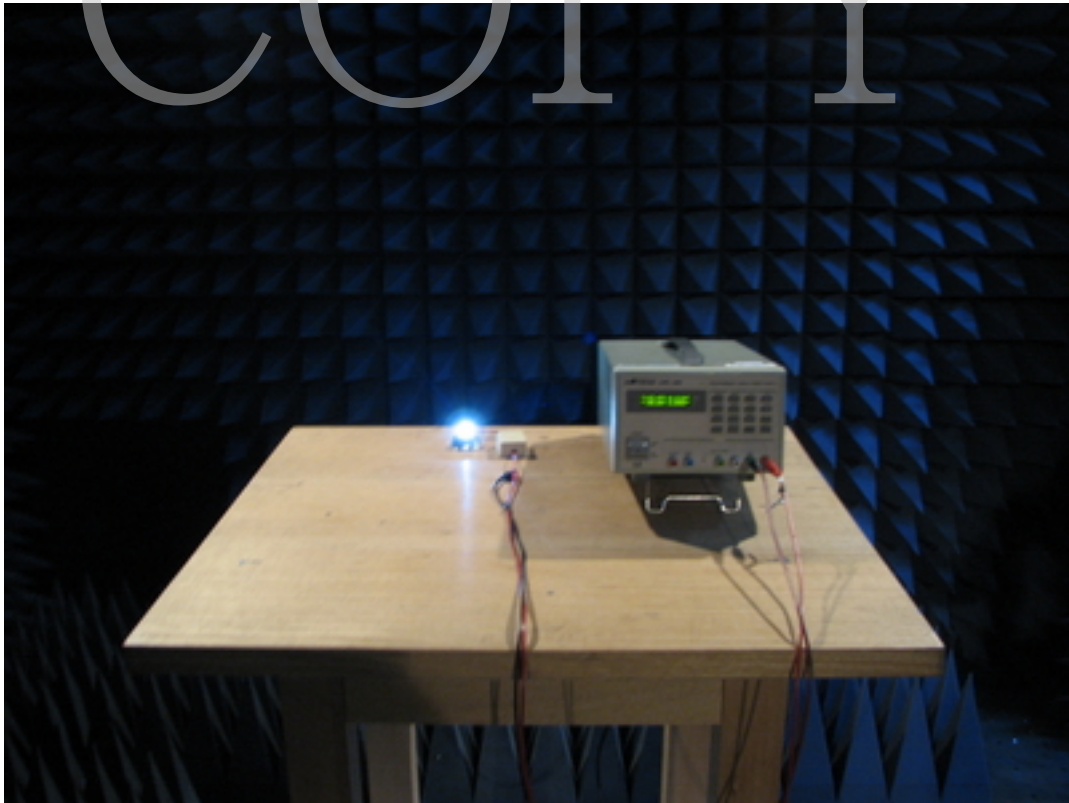

Registration number: W6M20707-8262-E-11